

# ISTRUZIONI DI MONTAGGIO

FITTING INSTRUCTIONS  
INSTRUCTIONS DE MONTAGE  
MONTAGEANLEITUNG  
INSTRUCCIONES DE MONTAJE



[www.umbrarimorchi.it](http://www.umbrarimorchi.it)

umbrarimorchi@umbrarimorchi.it

tel. +39 075 5280260

fax +39 075 5287033

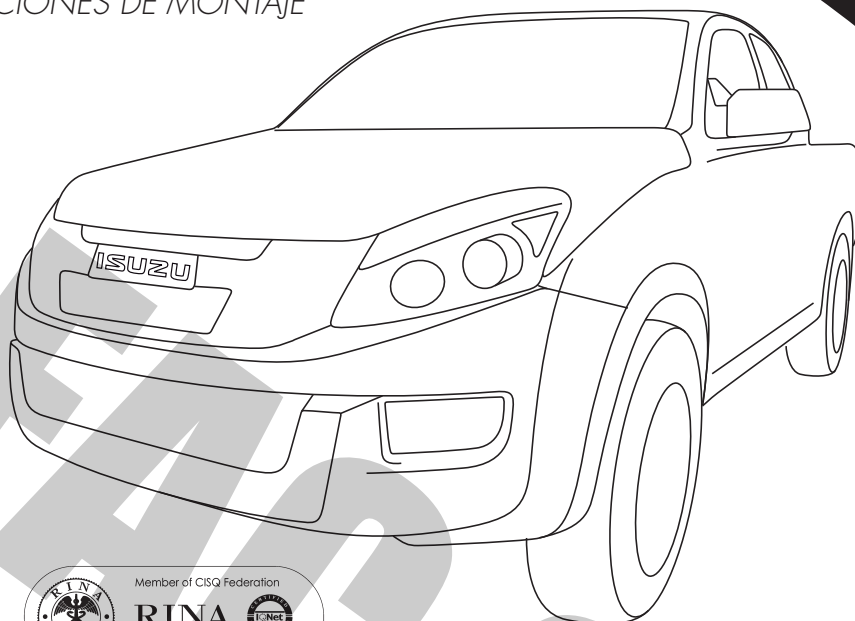

## NR.ART. 17007/SF

<b>DISPOSITIVO DI TRAIANO TIPO</b> TOWING BRACKET TYPE DISPOSITIF DE REMORQUAGE TYPE ANHAENGEVORRICHTUNG TYP DISPOSITIVO DE CAREO TIPO	<b>17007</b>
--	--------------

<b>PER AUTOVEICOLI</b> FOR CARS POUR AUTOS FÜR KRAFTFAHRZEUGE PARA AUTOVEHICULO	<b>ISUZU D-MAX 4x4</b> 4WD paraurti con gradino, no paraurti doppio tubolare, no 4x2 4WD step bumper, no double tubular bumper, no 4x2
---	--

<b>TYPE</b>	<b>ATFS 8</b>	<b>2012 =&gt;</b>
-------------	---------------	-------------------

<b>CLASSE E TIPO DI ATTACCO</b> CLASS AND HITCH TYPE CLASSE ET TYPE DE CROCHET KLASSE UND BEFESTIGUNGSART CLASES DE ACOPLAMIENTO	<b>OMOLOGAZIONE</b> HOMOLOGATION HOMOLOGATION ZULASSUNG APROBACION	<b>CARICO VERTICALE MAX</b> MAX VERTICAL MASS MASSE VERTICALE MAXIMUM ZUL. STUETZLAST CARGA MAX. VERTICAL
--	--	---

<b>F</b>	<b>e3 00 – 7668</b> (DIR. 94/20/CE)	<b>S = 150 kg</b>
----------	--	-------------------

<b>VALORE D</b> D VALUE VALEUR D D WERT VALOR D	<b>D = 15,5 kN</b>	$D = \frac{\text{Max } \downarrow \text{ Kg} \quad \text{Max } \downarrow \text{ Kg}}{\text{Max } \downarrow \text{ Kg} \quad \text{Max } \downarrow \text{ Kg}} \times 0,00981 \leq 15,5 \text{ kN}$
---	--------------------	---

<b>COPPIA DI SERRAGGIO PER VITI:</b> TORQUE SETTINGS FOR NUTS AND BOLTS: COUPLE D E SERRAGE POUR VIS: SCHRAUBENANZUGSMOMENT: MOM. DE PRESION PARA TORNILLOS Y TUERCAS:	M6 =10Nm    M8 =25Nm M10=55Nm    M12=85Nm M14=135Nm    M16=200Nm
---	--

## NOTE IMPORTANTI:

1. Prima dell'installazione assicurarsi che il dispositivo di traino in oggetto sia adatto per il veicolo sul quale lo si intende installare verificando che il n° di omologazione e di estensione oppure il tipo dell'autoveicolo, riportati sulla carta di circolazione, esista sul documento del gancio traino. In caso contrario consultare l'ufficio documenti per chiarimenti o richiesta di documenti aggiornati.
2. Il dispositivo di traino è un elemento di sicurezza e come tale deve essere installato solamente da un tecnico specializzato.
3. Elementi danneggiati o usurati devono essere sostituiti con ricambi originali da un tecnico specializzato.
4. E' proibito effettuare qualsiasi tipo di modifica significativa o riparazione alla struttura del dispositivo di traino.

## USO E MANUTENZIONE:

5. La sfera del dispositivo di traino deve essere mantenuta pulita e lubrificata. Per la massima sicurezza controllare saltuariamente il diametro della sfera; qualora il diametro della stessa, in diversi punti, sia ridotto a 49 mm il dispositivo di traino non potrà essere più utilizzato sino alla sostituzione della sopracitata sfera.
6. Dopo 1000 Km di traino tutta la bulloneria del dispositivo di traino deve essere controllata e riportata al valore di coppia di serraggio come indicato nella pagina delle istruzioni di montaggio.

### ATTENZIONE :

L'installatore del gancio di traino ha l'obbligo di fissare, all'altezza della sfera, in posizione ben visibile, una targhetta con l'indicazione del carico massimo sulla sfera prescritto per la vettura sulla quale viene montato il dispositivo di traino.

DISPOSITIVO DI TRAINO TIPO : <b>17007</b>
TIPO FUNZIONALE : <b>ATFS 8?? ??????????</b>
CARICO STATICO SU SFERA : <b>120 kg</b>
LARGHEZZA MAX RIMORCHIABILE : <b>2,55m</b>
MASSA RIMORCHIABILE : <b>(vedere nella carta di circolazione del veicolo)</b>
<b>DA COMPILARE PER IL COLLAUDO</b>
DICHIARAZIONE DI RESPONSABILITA' PER IL MONTAGGIO : Si dichiara che il presente dispositivo di traino tipo..... è stato montato a regola d'arte, rispettando le prescrizioni fornite sia del costruttore del veicolo che del costruttore del dispositivo di traino, sull'autoveicolo modello.....con targa.....  ..... , li ..... ( timbro e firma )
Si dichiara inoltre di aver informato l'utente del veicolo sull'USO e MANUTENZIONE del dispositivo stesso.

QUOTE: "e", "f"

GANCIO A SFERA A FLANGIA  
CLASSE "450.X"  
OMOLOGATO DIR. 94/20/CE

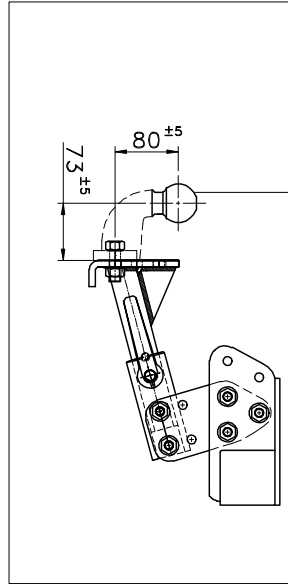

NR.ART.17007/SF

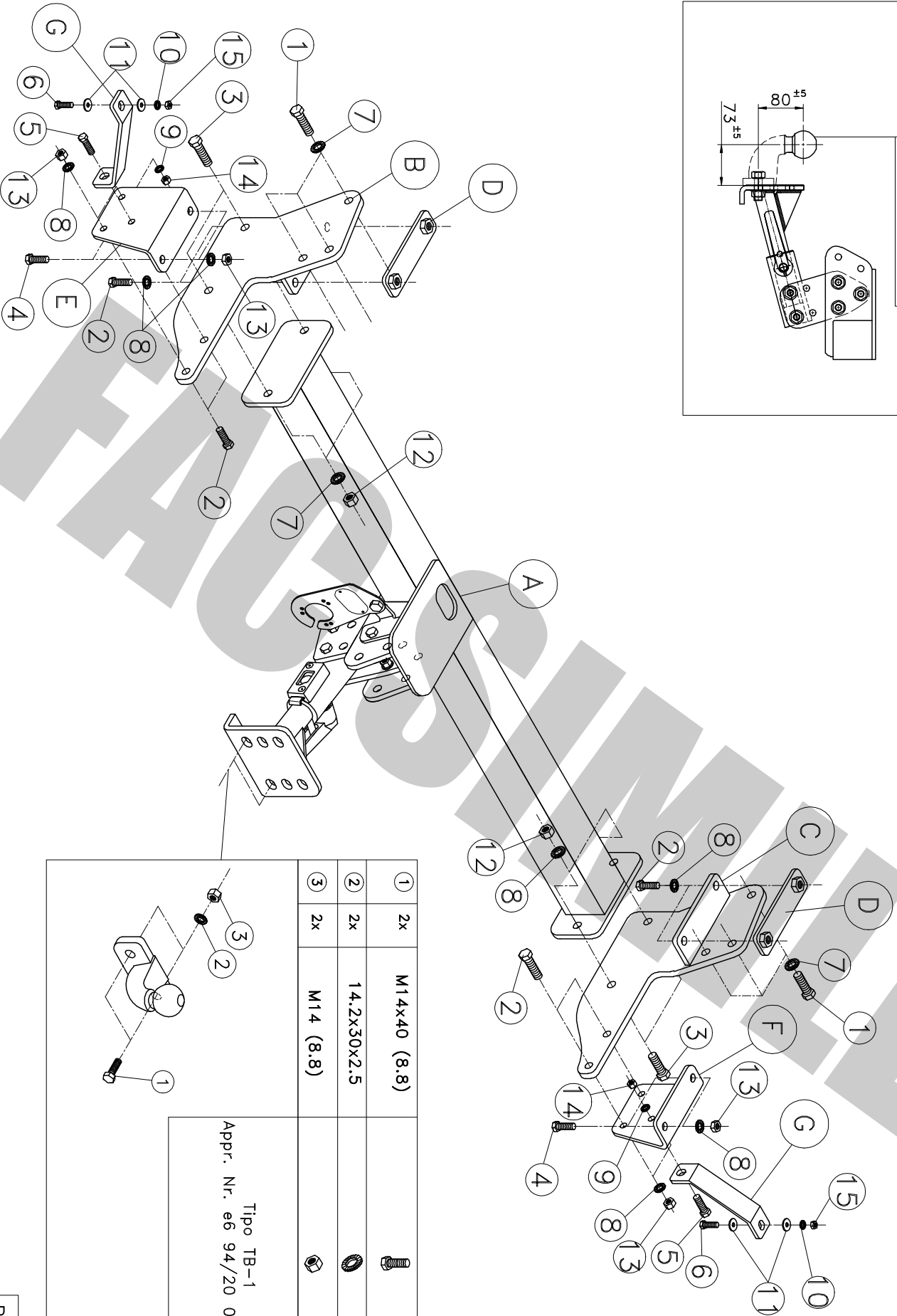



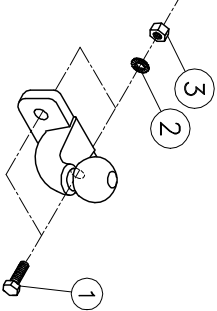





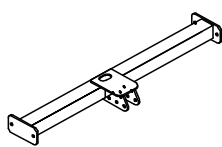
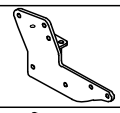
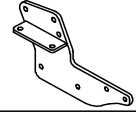











①	2x	M14x40 (8.8)	
②	2x	14.2x30x2.5	
③	2x	M14 (8.8)	



Tipo TB-1  
Appr. Nr. e6 94/20 010100

REV. 00

Ⓐ	1x	17007.B04	
Ⓑ	1x	17007.B06SX	
Ⓒ	1x	17007.B06DX	
Ⓓ	2x	17007.B08	
Ⓔ	1x	17007.B09SX	
Ⓕ	1x	17007.B09DX	
Ⓖ	2x	17007.B10	
①	6x	M12x35x1,25 (8.8)	
②	8x	M10x35 (8.8)	
③	4x	M12x35 (8.8)	
④	4x	M10x25 (8.8)	
⑤	2x	M8x25 (8.8)	
⑥	2x	M6x20 (8.8)	
⑦	10x	12.2x27x2	
⑧	12x	10.2x22x2	
⑨	2x	8.2x16x1,5	
⑩	2x	6.2x14x1,5	
⑪	4x	6.2x18x1,5	
⑫	4x	M12 (8.8)	
⑬	8x	M10 (8.8)	
⑭	2x	M8 (8.8)	
⑮	2x	M6 (8.8)	

REV.00

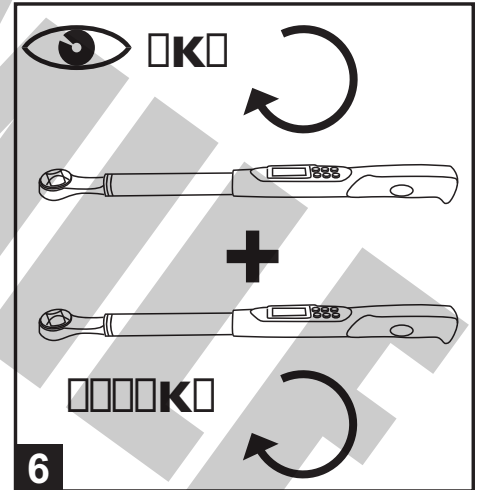
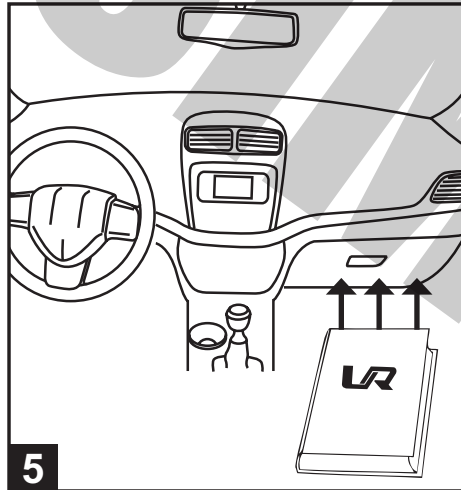
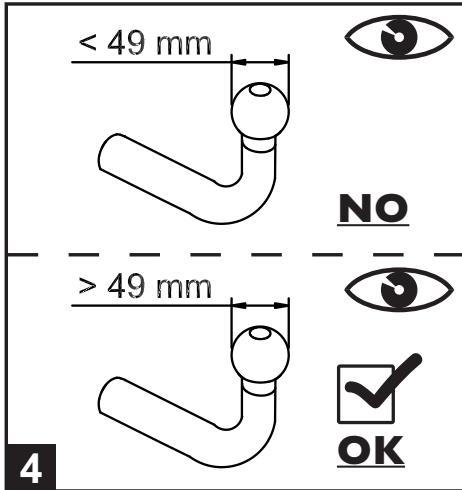
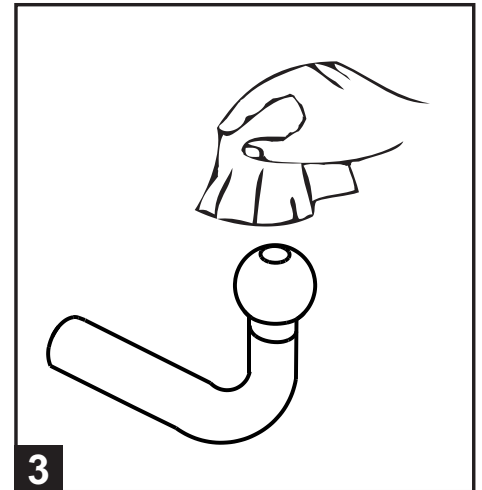
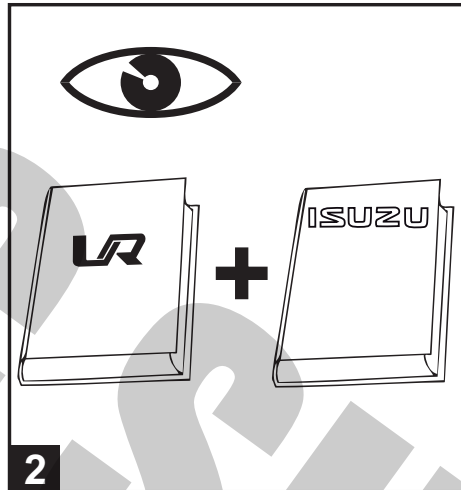
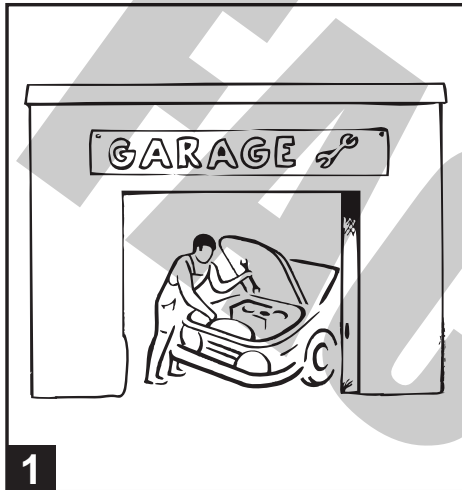

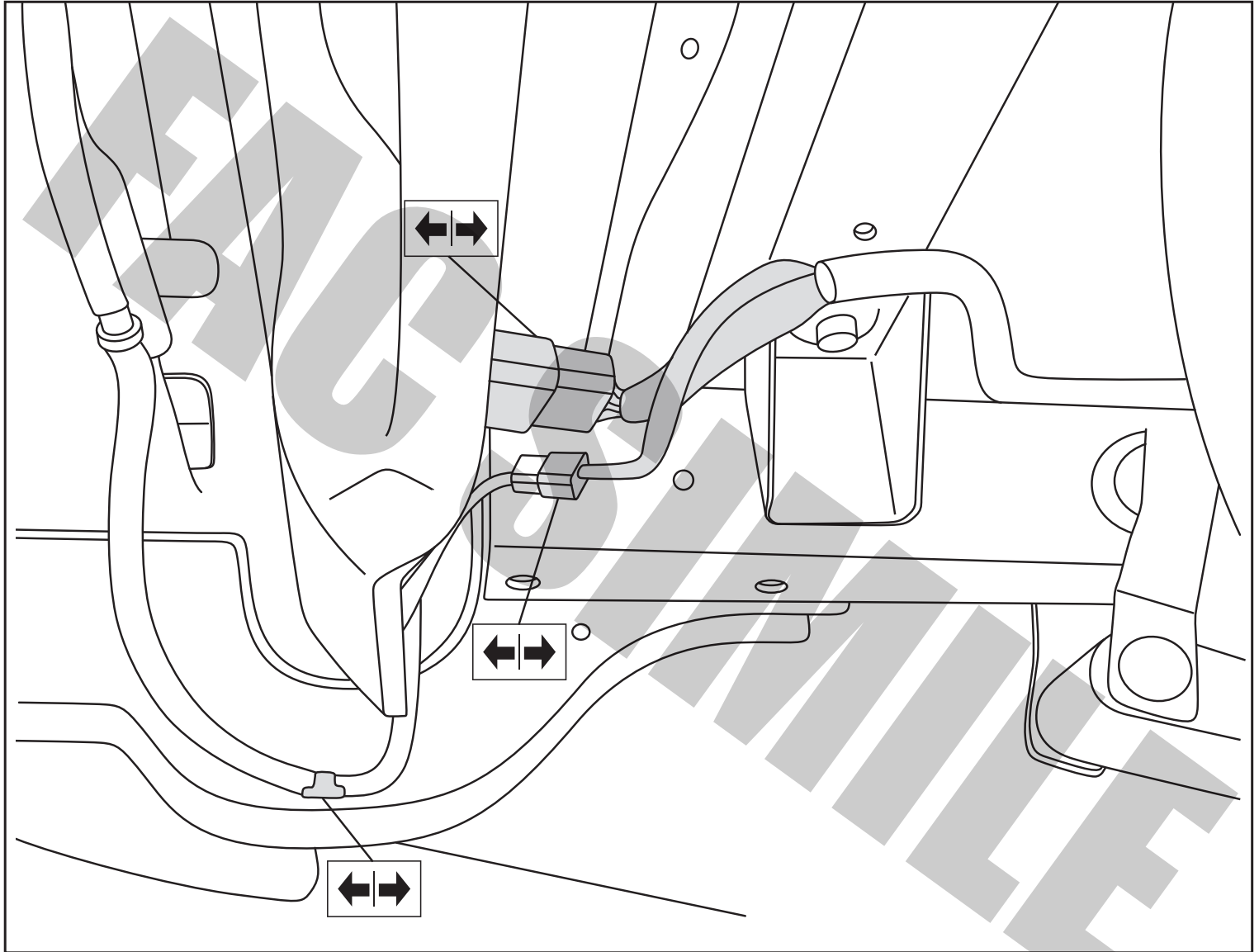

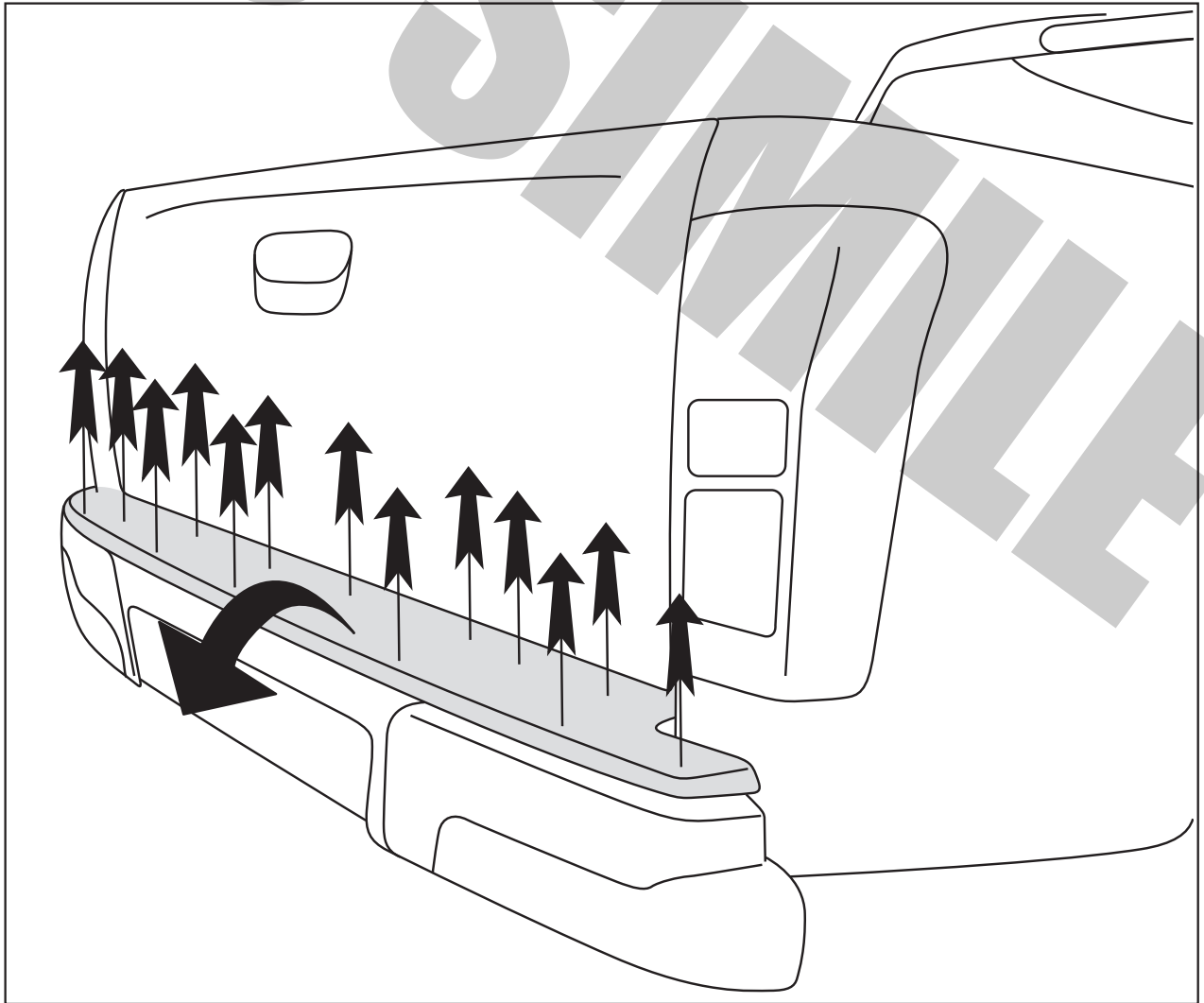
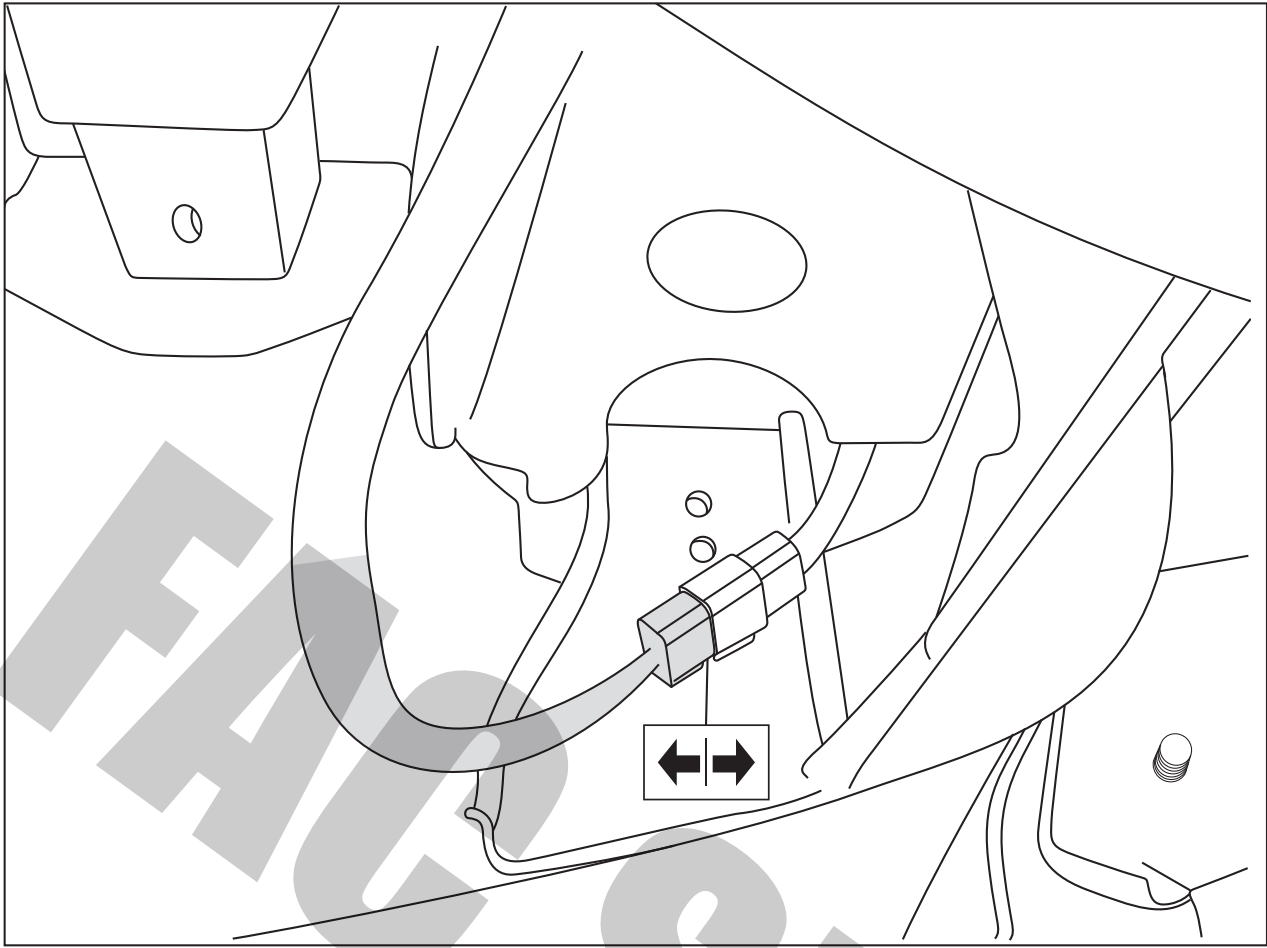

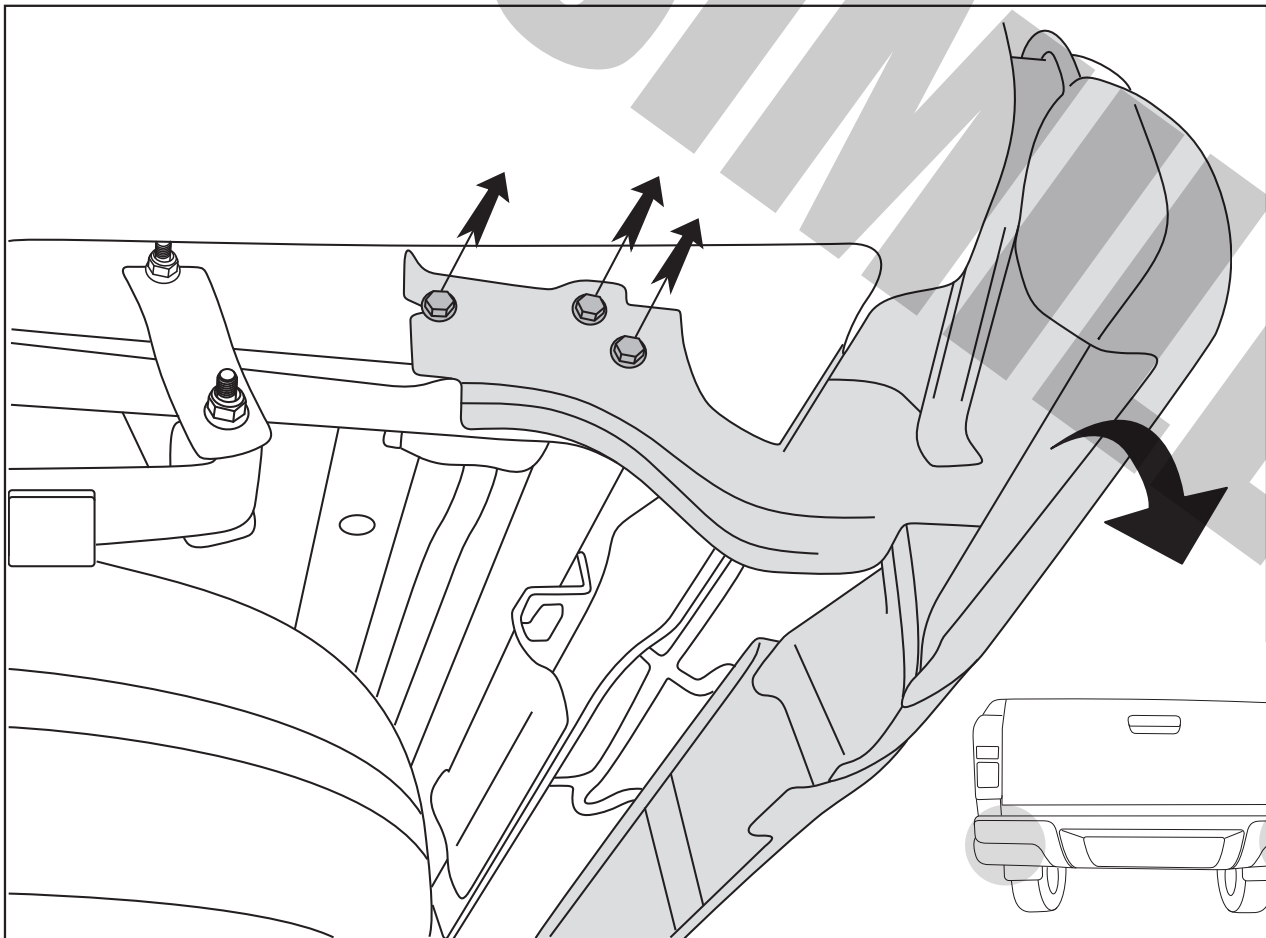
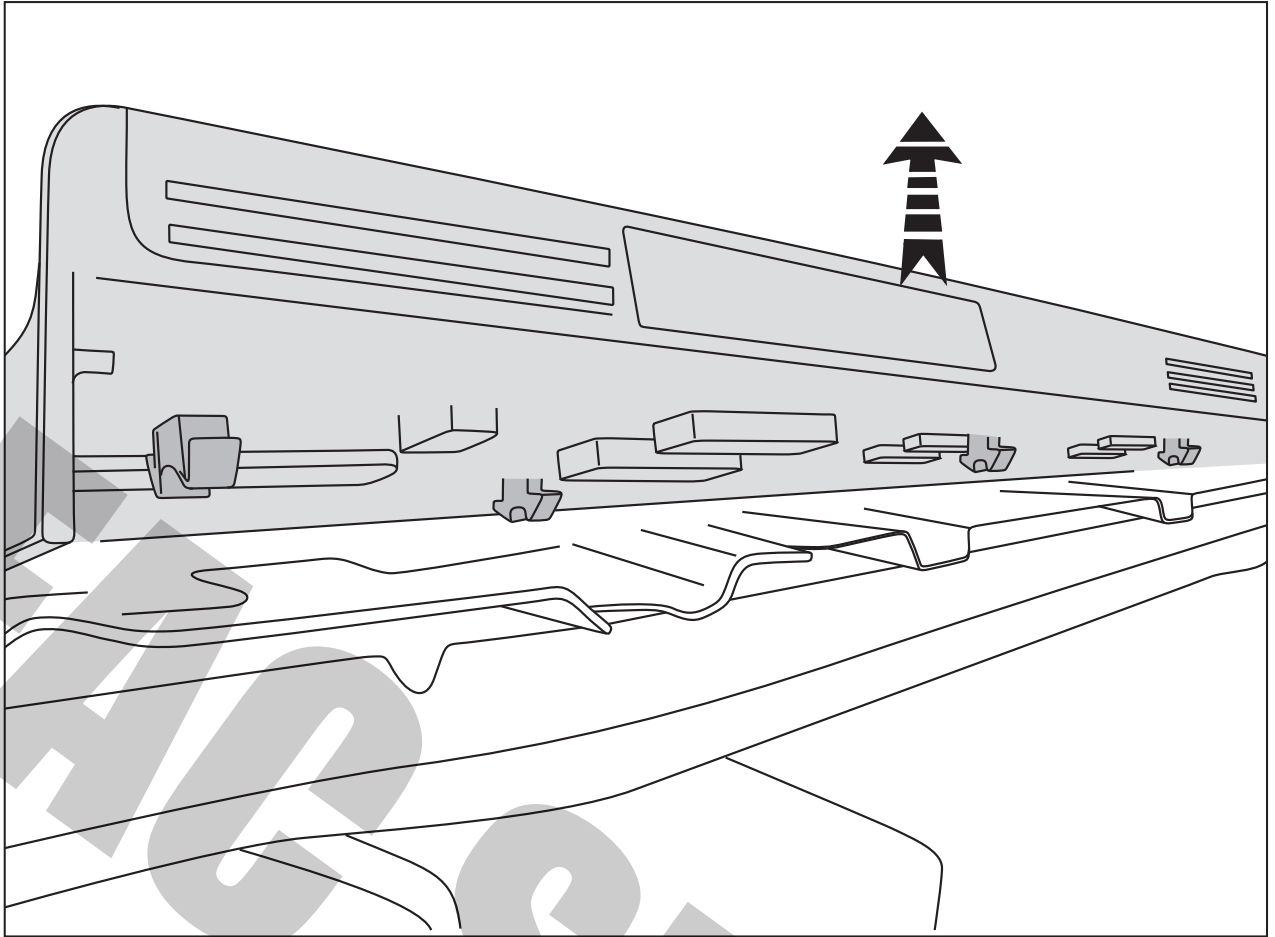



**x3**  
M12x35x1,25 (8.8)  
12.2x27x2

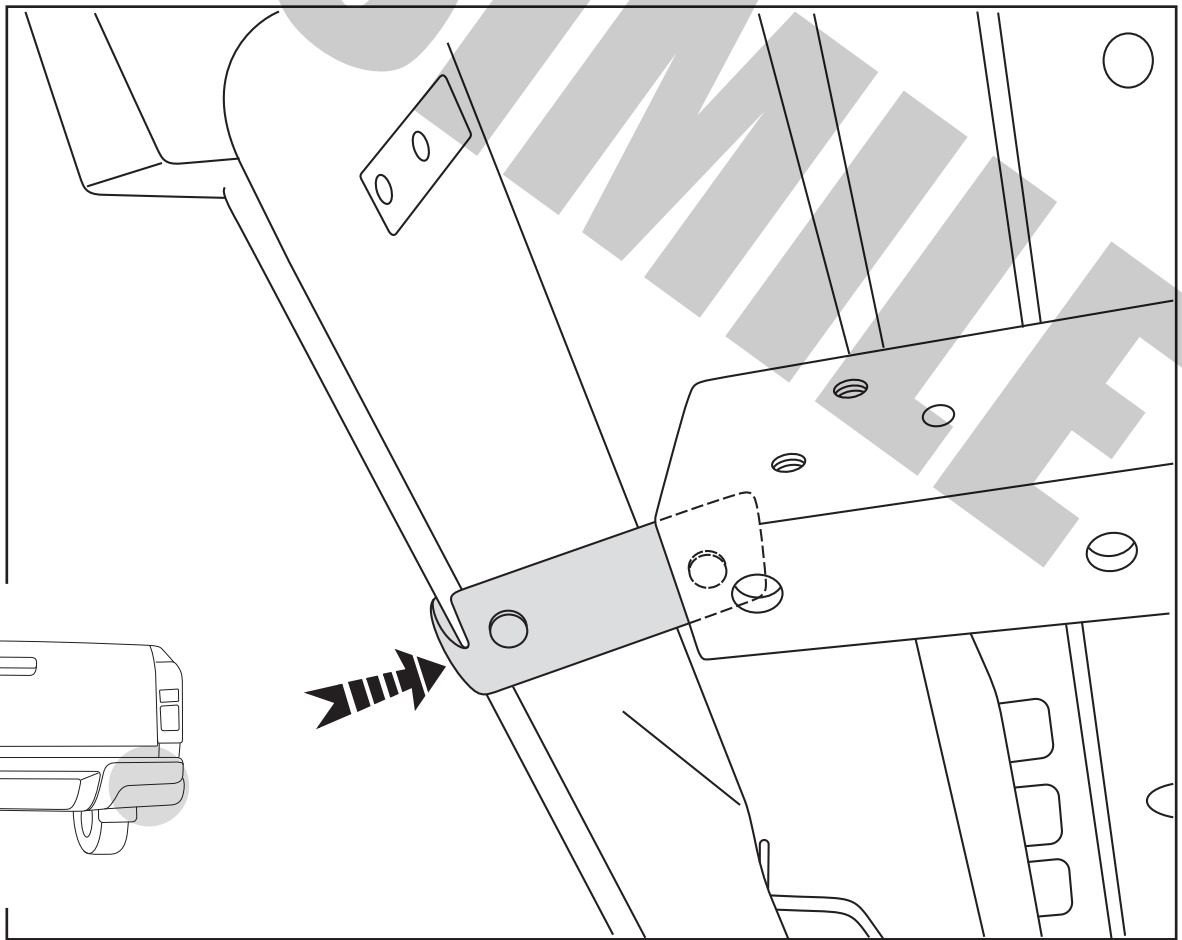
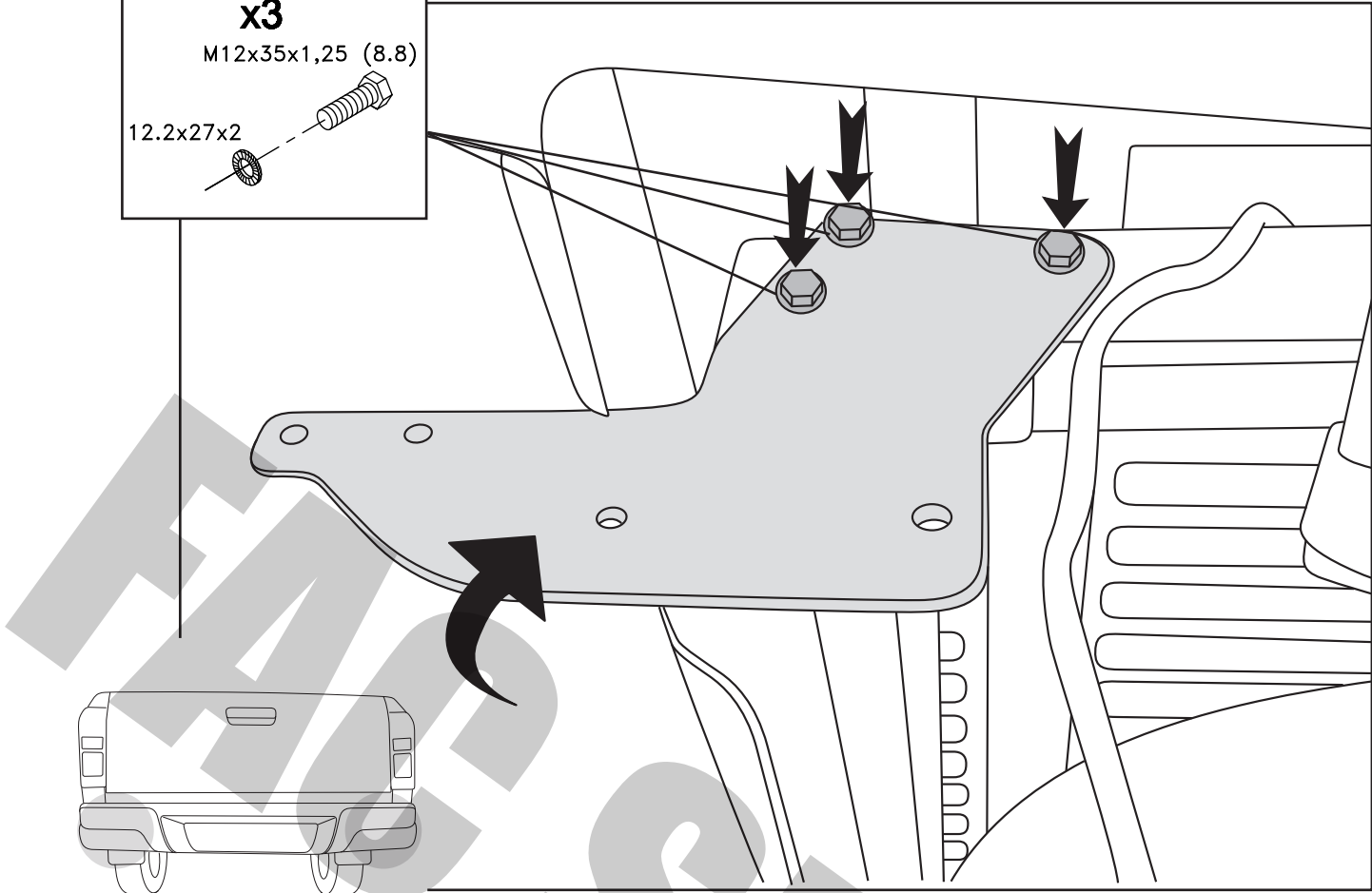

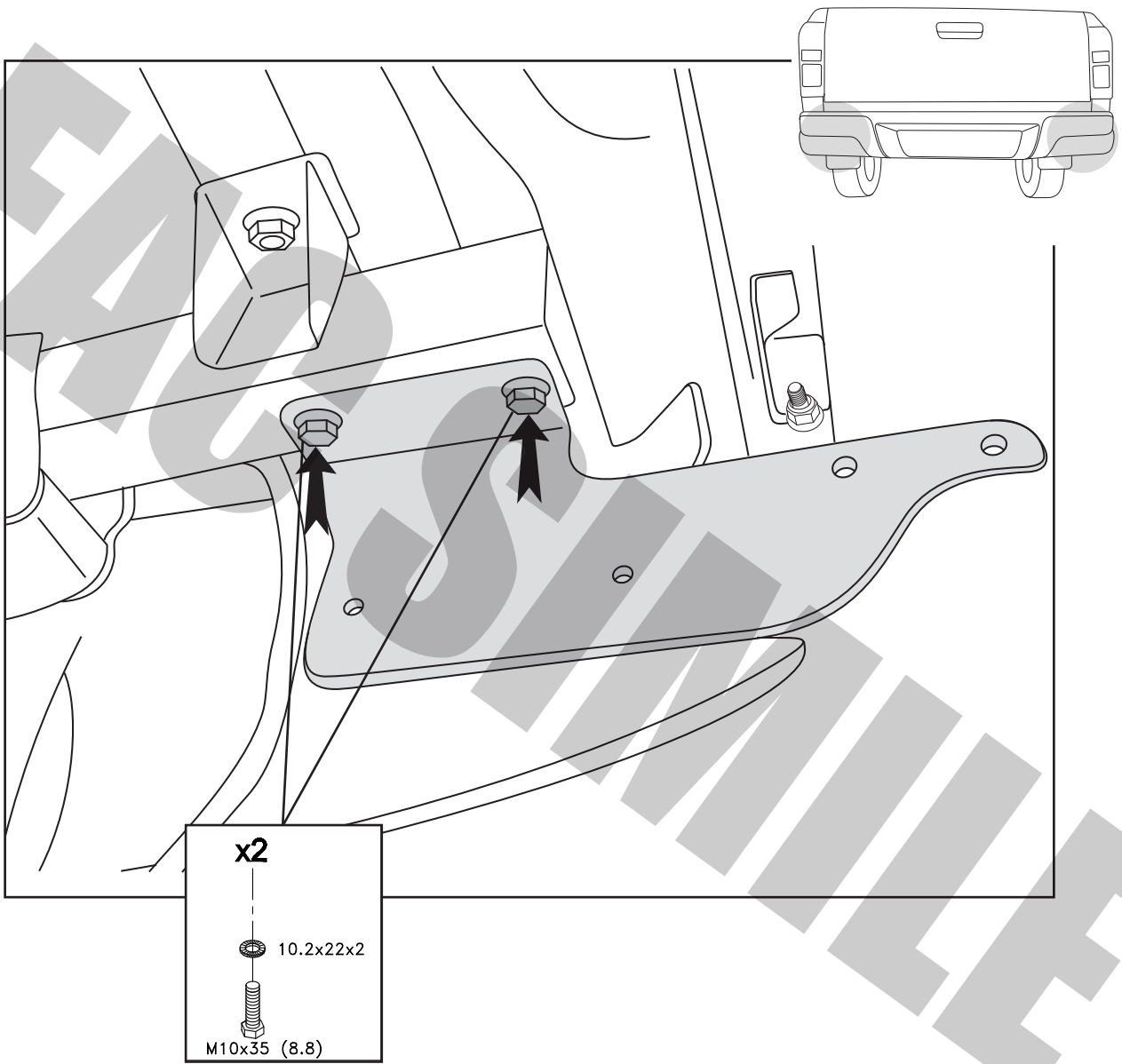

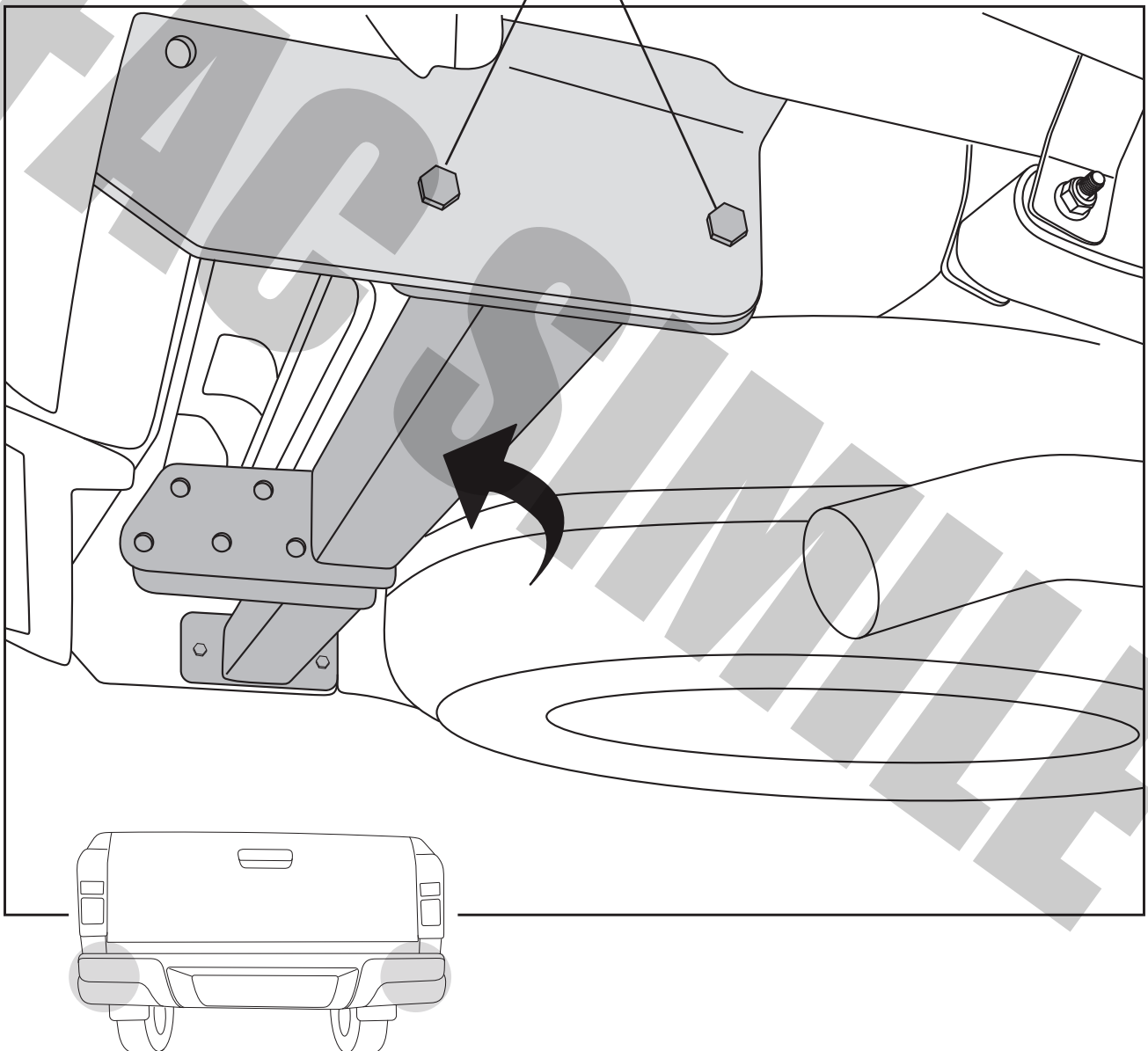
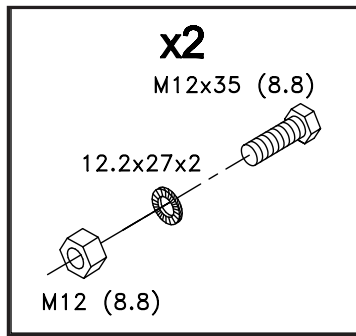

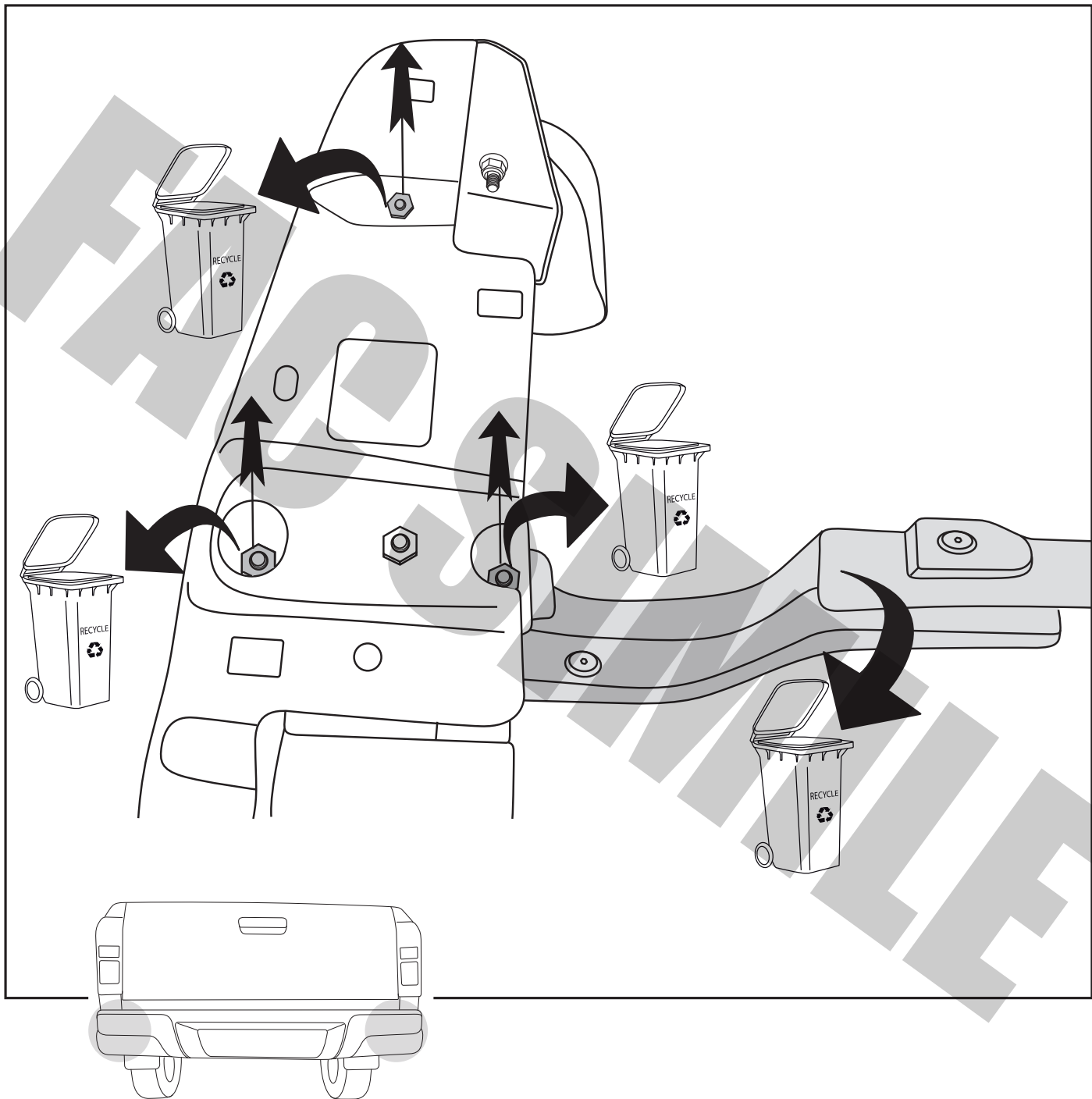

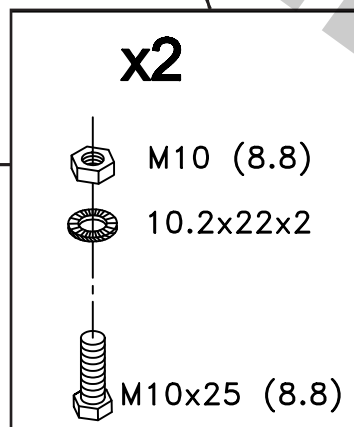
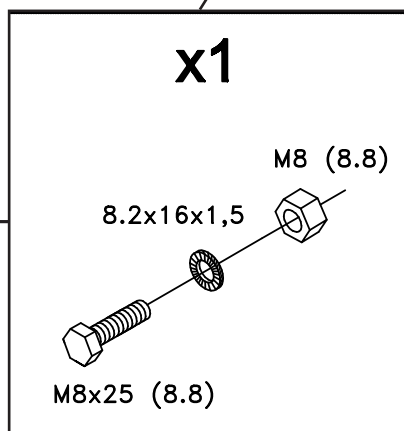
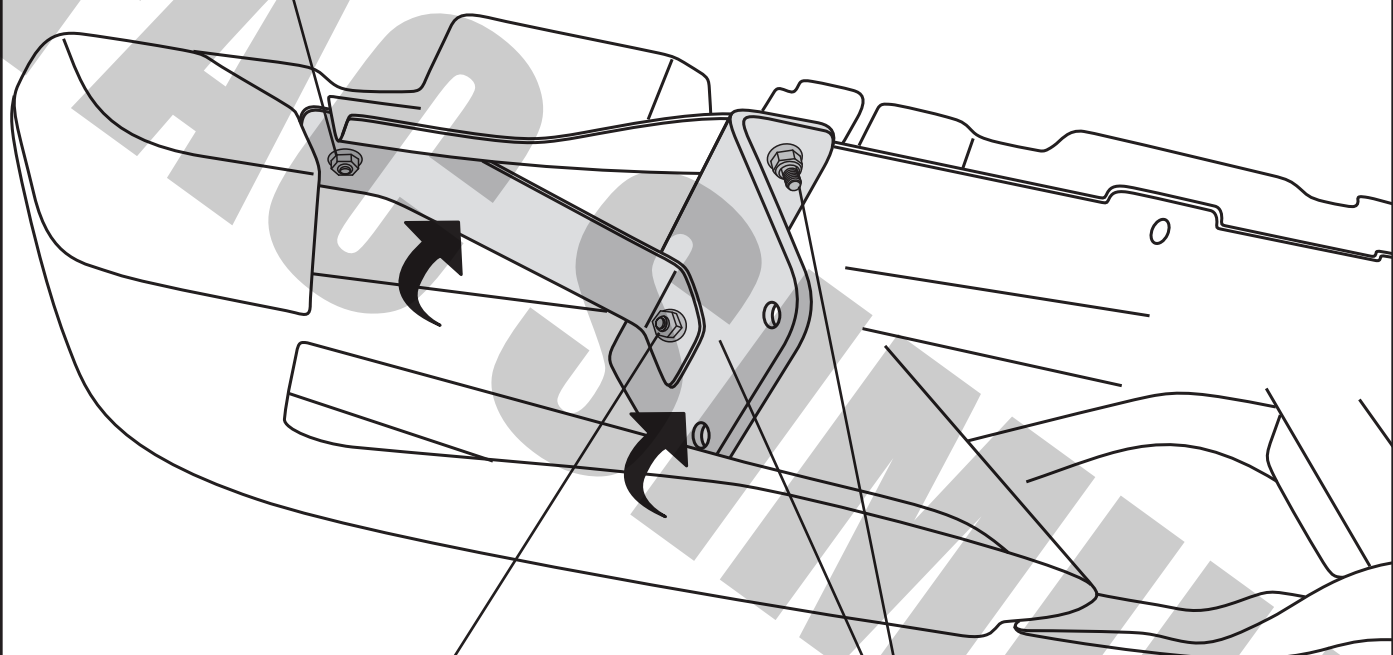
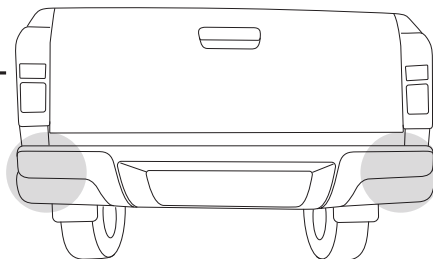
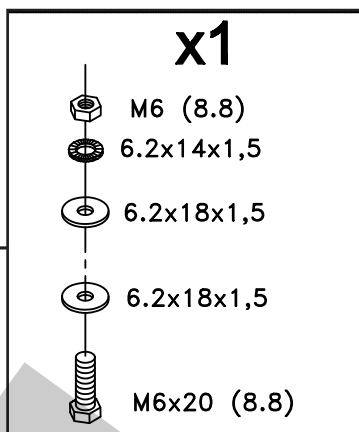

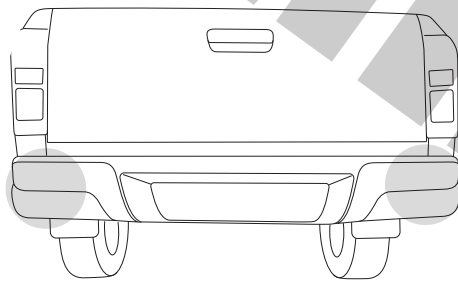
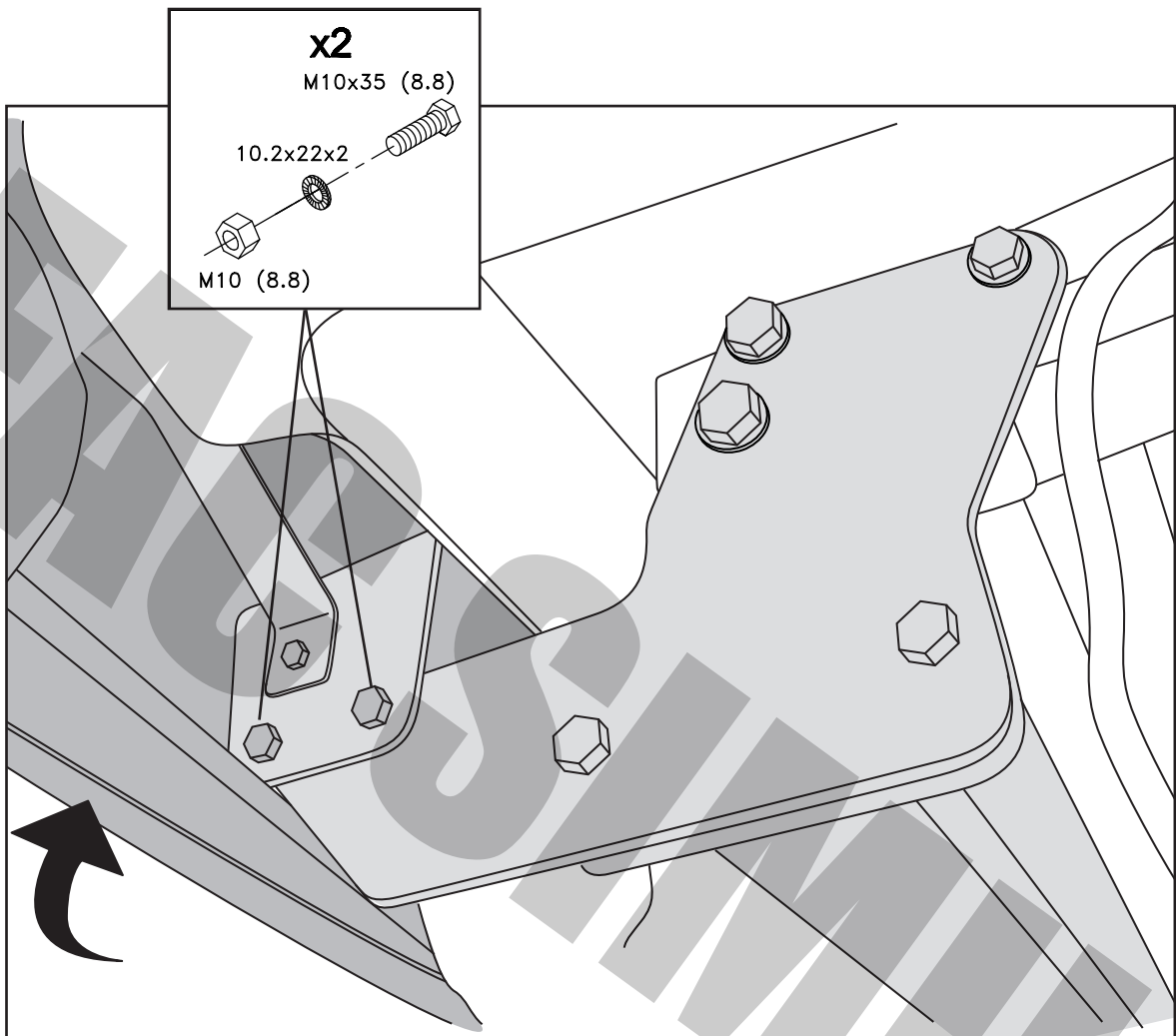

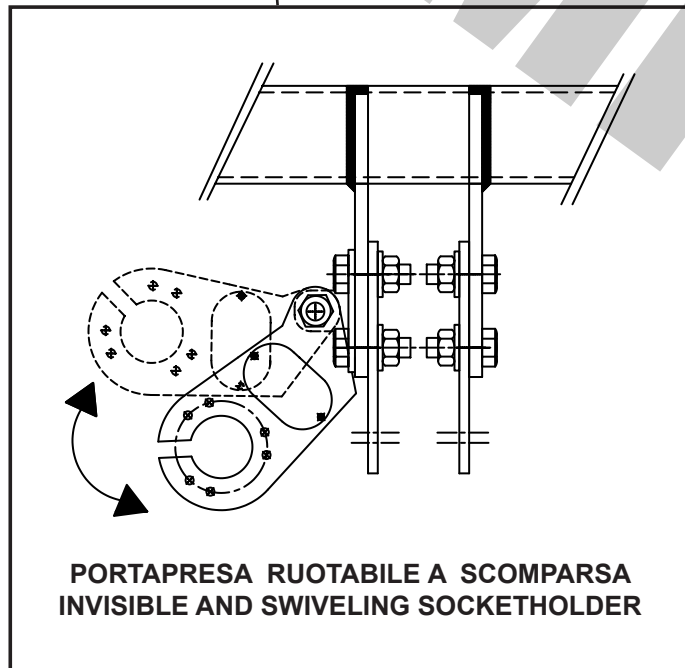
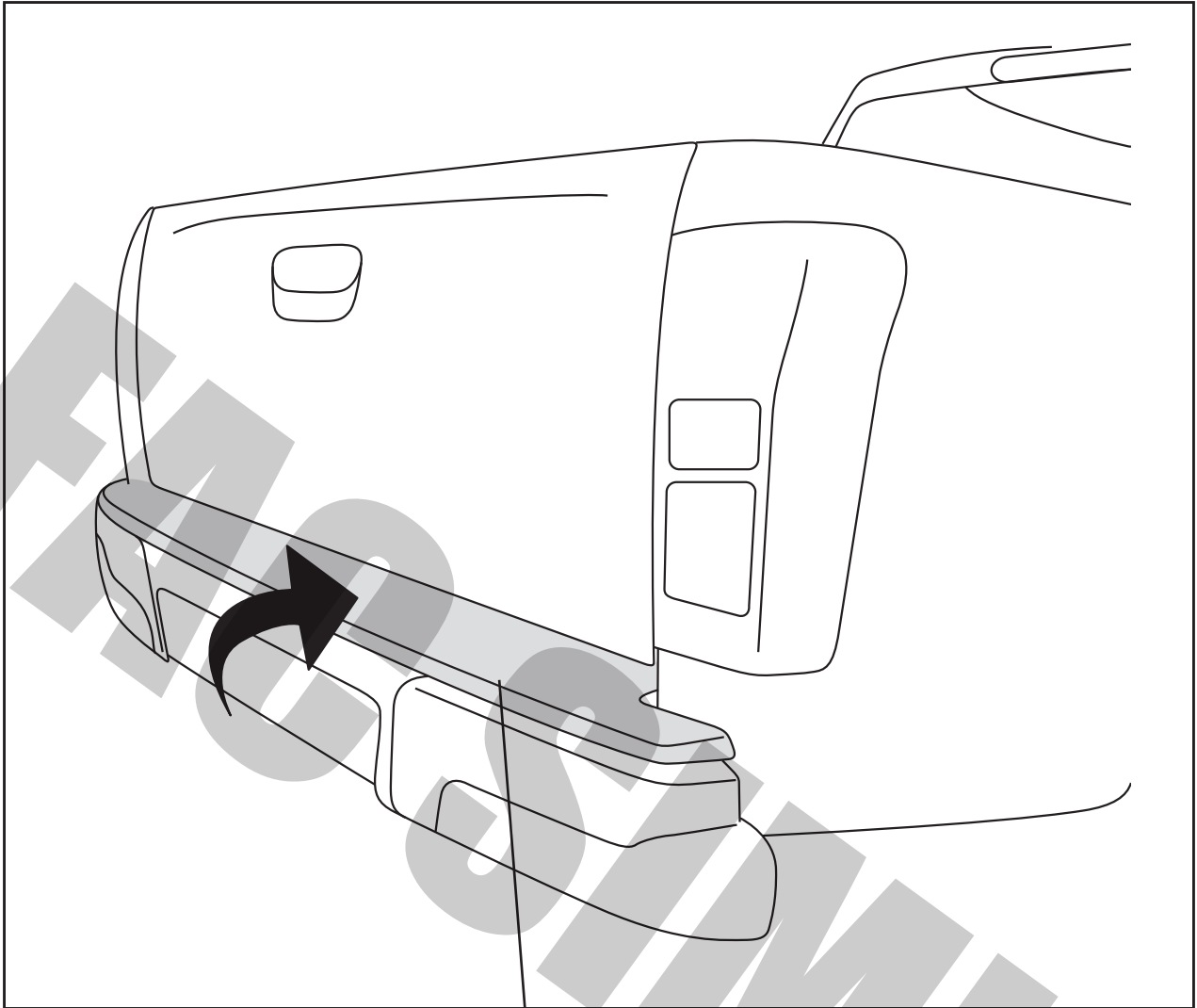

# MECCANISMO MOD. C 2007

<b>NL</b> - Demontage	<b>S</b> - Demontering	<b>I</b> - Smontaggio
<b>GB</b> - Disounting	<b>DK</b> - Frakobling	
<b>D</b> - Demontage	<b>FIN</b> - Irrotta	
<b>F</b> - Démontage	<b>E</b> - Desmontaje	

<b>NL</b> - Montage	<b>S</b> - Montering	<b>I</b> - Montaggio
<b>GB</b> - Mounting	<b>DK</b> - Tilkobling	
<b>D</b> - Montage	<b>FIN</b> - Asennus	
<b>F</b> - Montage	<b>E</b> - Montaje	

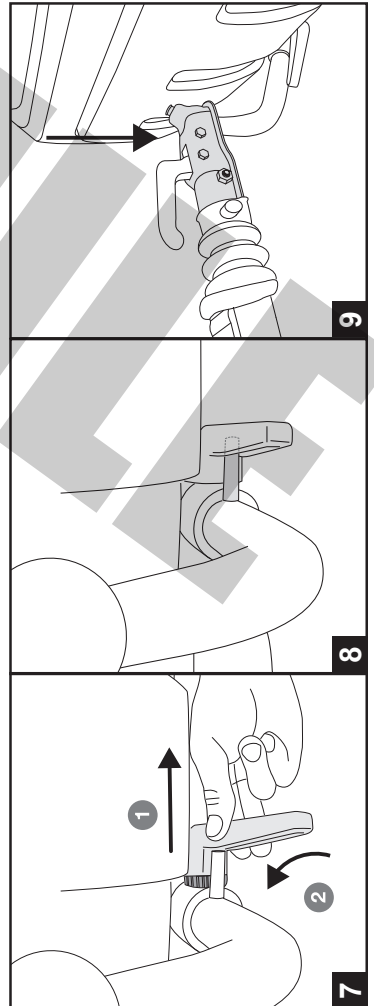
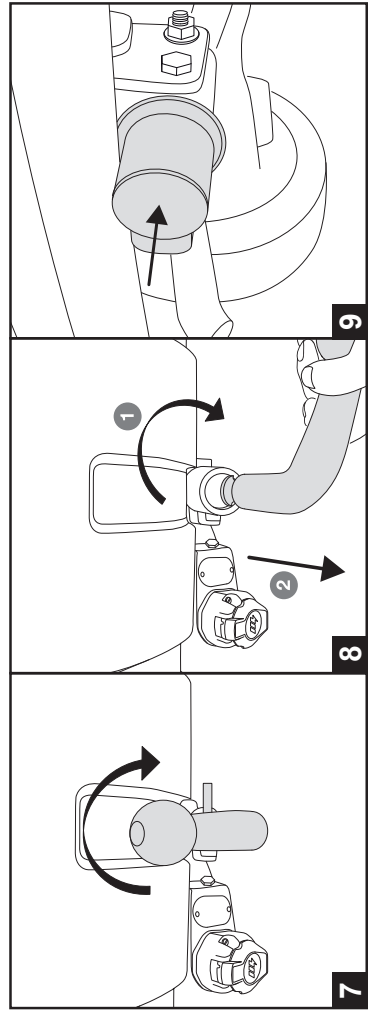
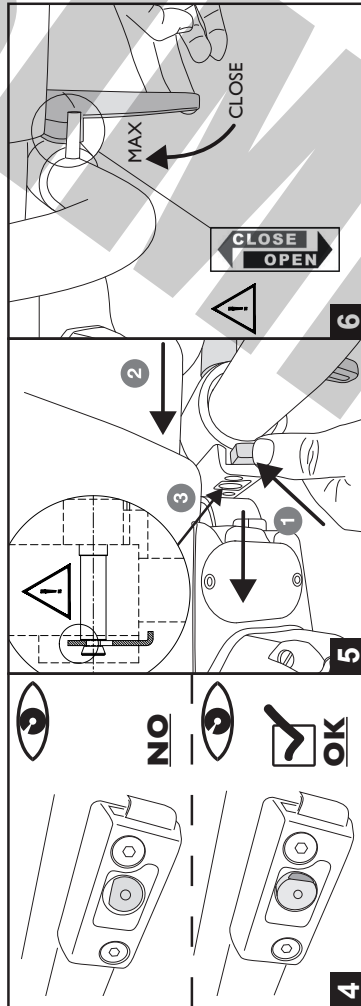
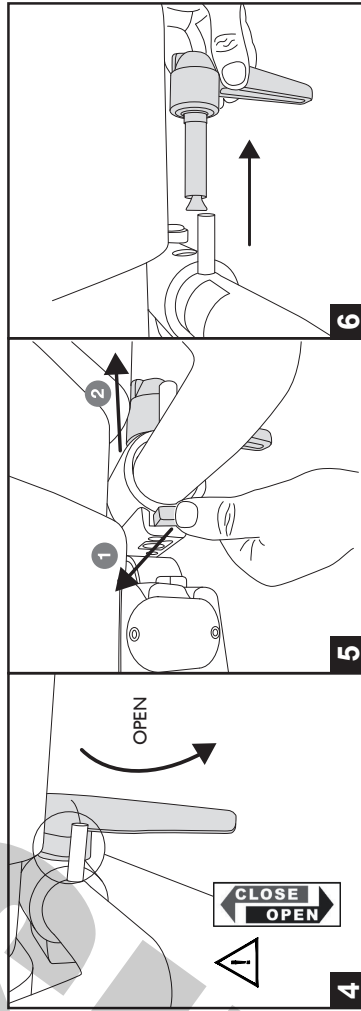
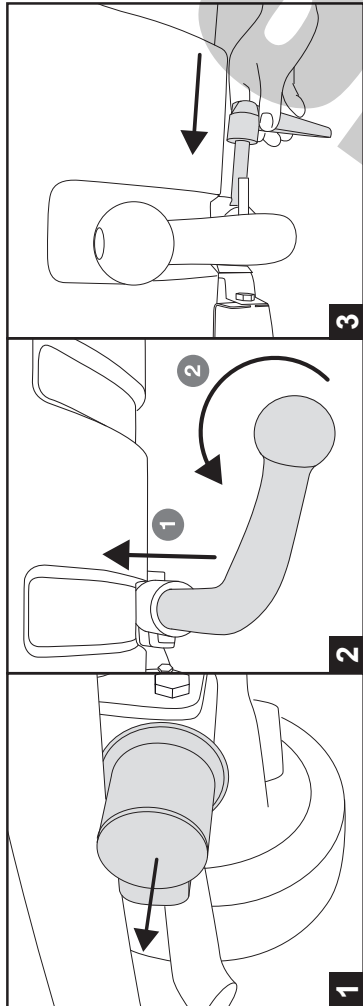
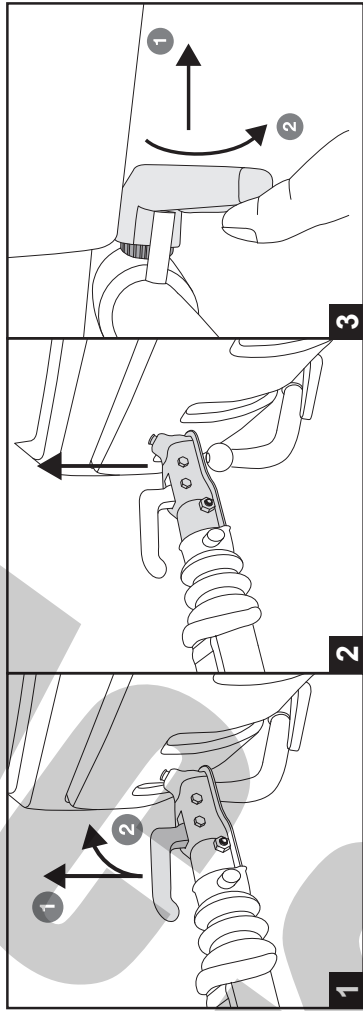



- D** Der Freiraum nach Anhang VII, Abbildung 30 der Richtlinie 94/20/EG ist zu gewährleisten.
- CZ** Volný prostor ve smyslu Přílohy VII, obr. 30 Směrnice č. 94/20/EG musí být zaručen.
- DK** Frirommet skal overholdes iht. bilag VII, fig. 30 i direktiv 94/20/EF.
- E** Debe garantizarse el espacio libre, conforme al anexo VII, imagen 30 de la directiva comunitaria 94/20/CE.
- F** L'espace libre doit être garanti conformément à l'annexe VII, illustration 30 de la directive 94/20/CE.
- FIN** Liitteen VII, direktiivin 94/20/EY kuvan 30 mukainen vapaatila on taattava.
- GB** The clearance specified in appendix VII, diagram 30 of guideline 94/20/EC must be guaranteed.
- GR** Πρέπει να εξασφαλίζεται ο ελεύθερος χώρος σύμφωνα με το Παράρτημα VII, εικόνα 30 της Οδηγίας 94/20/ΕΚ.
- I** Deve essere garantito lo spazio libero secondo l'allegato VII, figura 30 della direttiva 94/20/CE.
- N** Frirommet etter tillegg VII, figur 30 i direktiv 94/20/EØF skal overholdes.
- NL** De tussenruimte volgens aanhangsel VII, afbeelding 30 van de richtlijn 94/20/EG moet in acht worden genomen.
- PL** Zagwarantować swobodną przestrzeń zgodnie z załącznikiem VII, rysunek 30 dyrektywy 94/20/CE.
- S** Glappet enligt bilaga VII, bild 30 i direktiv 94/20/EG ska garanteras.

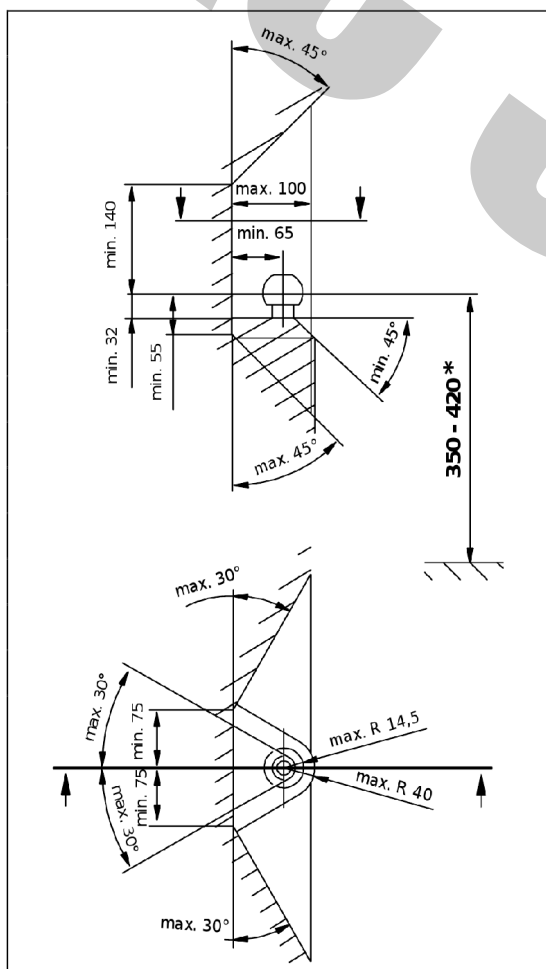

- D** \* bei zulässigem Gesamtgewicht des Fahrzeuges
- CZ** \* při celkové přípustné hmotnosti vozidla
- DK** \* ved tilladt totalvægt for køretøjet
- E** \* con peso total autorizado del vehículo
- F** \* pour poids total en charge autorisé du véhicule
- FIN** \* Ajoneuvon suurimmalla sallitulla kokonaispainolla
- GB** \* at gross vehicle weight rating
- GR** \* για το επιτρεπτό μικτό βάρος του οχήματος
- I** \* per il peso complessivo ammesso del veicolo
- N** \* ved kjøretøyets tillatte totalvekt
- NL** \* bij toegestaan totaal gewicht van het voertuig
- PL** \* przy dopuszczalnym ciężarze całkowitym pojazdu
- S** \* vid fordonets tillåtna totalvikt



[umbrarimorchi.pl](http://umbrarimorchi.pl)